

Elektrische Eigenschaften / Electrical properties

Höchstzulässige Werte / Maximum rated values

Periodische Spitzensperrspannung repetitive peak reverse voltage	$t_{vj} = -40^{\circ}\text{C} \dots t_{vj\text{ max}}$	V_{RRM}	3500, 4000 4500	V
Stoßspitzensperrspannung non-repetitive peak reverse voltage	$t_{vj} = +25^{\circ}\text{C} \dots t_{vj\text{ max}}$	V_{RSM}	3600, 4100 4600	V
Durchlaßstrom-Grenzeffektivwert RMS forward current		I_{FRMSM}	2700	A
Dauergrenzstrom mean forward current	$t_C = 85^{\circ}\text{C}, f = 50\text{Hz}$ $t_C = 70^{\circ}\text{C}, f = 50\text{Hz}$	I_{FAVM}	1460 1720	A A
Stoßstrom-Grenzwert surge forward current	$t_{vj} = t_{vj\text{ max}}, t_p = 10\text{ms}$	I_{FSM}	32	kA
Grenzlastintegral I^2t -value	$t_{vj} = t_{vj\text{ max}}, t_p = 10\text{ms}$	I^2t	$5,12 \cdot 10^6$	A^2s
Period. Abklingsteilheit des Durchlaßstroms beim Ausschalten repetitive decay rate of on-state current at turn-off	$i_{FM} = 3000\text{A}, v_R = 0,67 V_{RRM}$ $C_S = 3\mu\text{F}, R_S = 4\Omega$ $D_S = D291S45T$	$(-di_F/dt)_{com}$	500	$\text{A}/\mu\text{s}$

Charakteristische Werte / Characteristic values

Gleichsperrspannung continuous direct reverse voltage	failure rate $\lambda < 100$ estimate value	$V_{R(D)}$	typ. 2000	V
Durchlaßspannung forward voltage	$t_{vj} = t_{vj\text{ max}}, i_F = 2500\text{A}$	v_F	max 2,5	V
Schleusenspannung threshold voltage	$t_{vj} = t_{vj\text{ max}}$	$V_{(TO)}$	1,43	V
Ersatzwiderstand forward slope resistance	$t_{vj} = t_{vj\text{ max}}$	r_T	0,38	$\text{m}\Omega$
Spitzenwert der Durchlaßverzögerungsspannung peak value of forward recovery voltage	$t_{vj} = t_{vj\text{ max}}, di_F/dt = 500\text{A}/\mu\text{s}$	V_{FRM}	typ. 45	V
Sperrstrom reverse current	$t_{vj} = t_{vj\text{ max}}, v_R = V_{RRM}$	i_R	200	mA
Rückstromspitze peak reverse recovery current	$t_{vj} = t_{vj\text{ max}}$ $i_{FM} = 1000\text{A}, -di_F/dt = 250\text{A}/\mu\text{s}$ $v_R = 1000\text{V}, C_S = 3,3\mu\text{F}, R_S = 5\Omega$	I_{RM}	max 840	A
Sperrverzögerungsladung recovered charge	$t_{vj} = t_{vj\text{ max}}$ $i_{FM} = 1000\text{A}, -di_F/dt = 250\text{A}/\mu\text{s}$ $v_R = 1000\text{V}, C_S = 3,3\mu\text{F}, R_S = 5\Omega$	Q_r	max 2800	μAs

Technische Information / Technical Information

eupec

Schnelle Gleichrichterdiode
Fast Diode

D 1461 S 35 ... 45 T

S

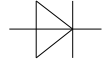

Thermische Eigenschaften / Thermal properties

Innerer Wärmewiderstand thermal resistance, junction to case	Kühlfläche / cooling surface beidseitig / two-sided, DC Anode / anode, DC Kathode / cathode, DC	R_{thJC}	max 0,0125 max 0,0228 max 0,0277	°C/W °C/W °C/W
Übergangs-Wärmewiderstand thermal resistance, case to heatsink	Kühlfläche / cooling surface beidseitig / two-sided einseitig / single sided	R_{thCK}	max 0,003 max 0,006	°C/W °C/W
Höchstzulässige Sperrschichttemperatur max. junction temperature		$t_{vj \max}$	140	°C
Betriebstemperatur operating temperature		$t_{c \text{ op}}$	-40...+140	°C
Lagertemperatur storage temperature		t_{stg}	-40...+150	°C

Mechanische Eigenschaften / Mechanical properties

Gehäuse, siehe Anlage case, see appendix			Seite 3	
Anpreßkraft clampig force		F	27...45	kN
Gewicht weight		G	typ 850	g
Kriechstrecke creepage distance			30	mm
Luftstrecke air distance			20	mm
Feuchtklasse humidity classification	DIN 40040		C	
Schwingfestigkeit vibration resistance	f = 50Hz		50	m/s ²

Mit dieser technischen Information werden Halbleiterbauelemente spezifiziert, jedoch keine Eigenschaften zugesichert. Sie gilt in Verbindung mit den zugehörigen technischen Erläuterungen.
This technical information specifies semiconductor devices but promises no characteristics. It is valid in combination with the belonging technical notes.

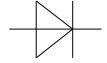

Outline Drawing

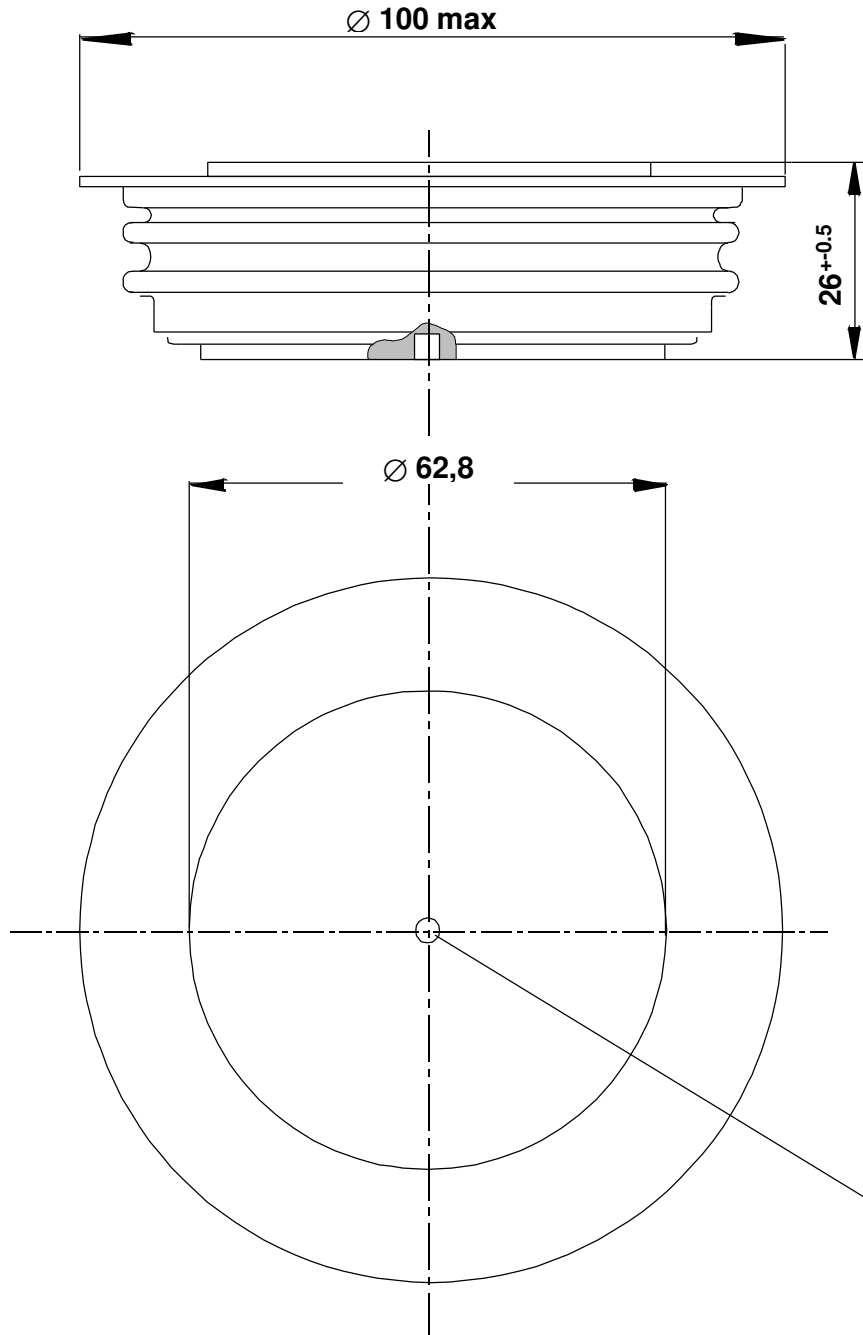

A
C

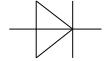

On-State Characteristics (v_F)
Upper limit of scatter range

— $t_{vj} = 140^\circ C$

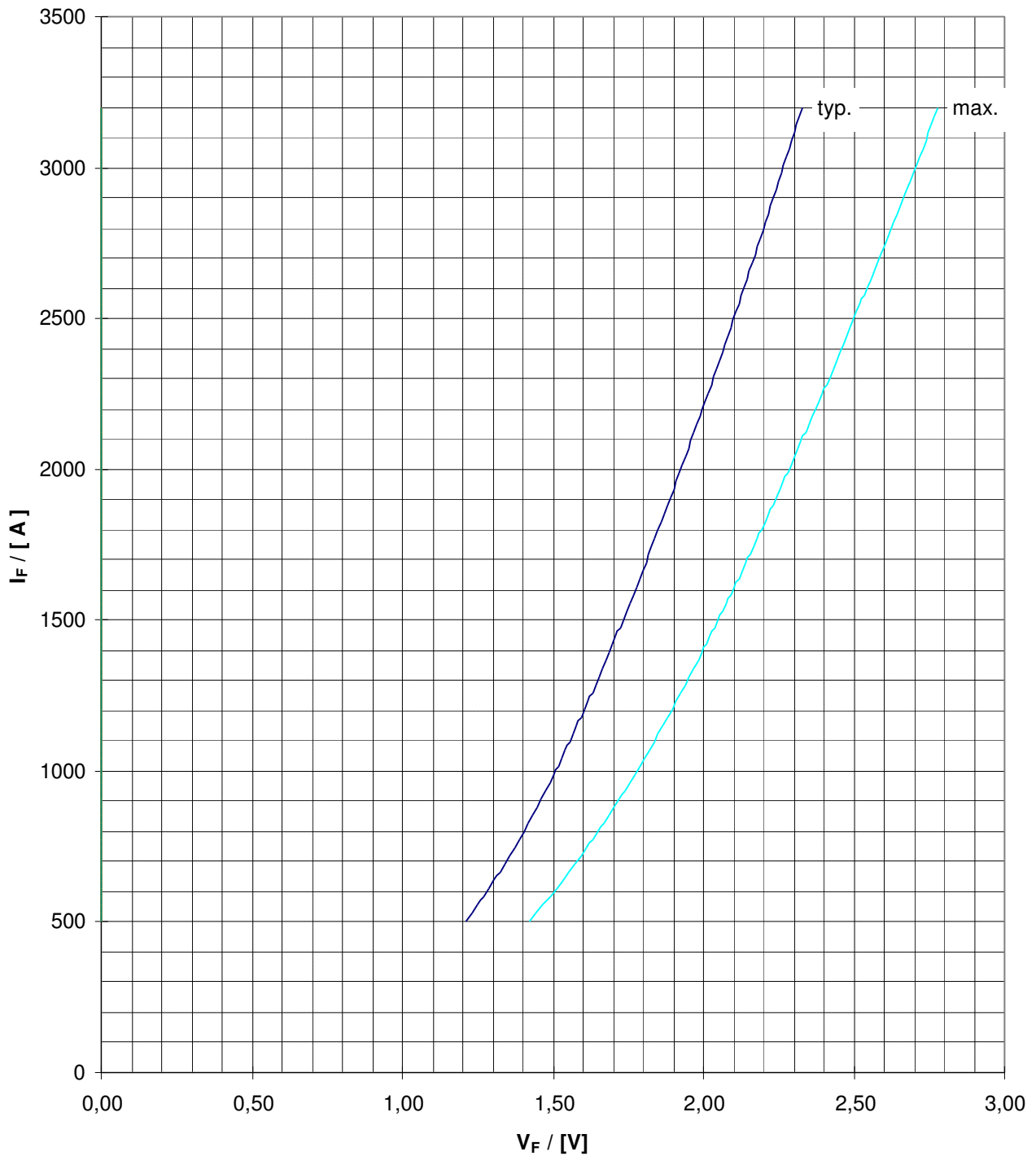

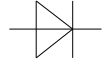

Transient thermal Impedance for constant-current

	Double side cooled		Anode side cooled		Cathode side cooled	
	r [K/W]	[s]	r [K/W]	[s]	r [K/W]	[s]
1	0,0038	2	0,0141	9,2	0,019	7,9
2	0,004	0,202	0,004	0,202	0,004	0,202
3	0,0029	0,103	0,0029	0,103	0,0029	0,13
4	0,0012	0,0115	0,0012	0,0115	0,0012	0,0115
5	0,0006	0,00245	0,0006	0,00245	0,0006	0,00245
Σ	0,0125	-	0,0228	-	0,0277	-

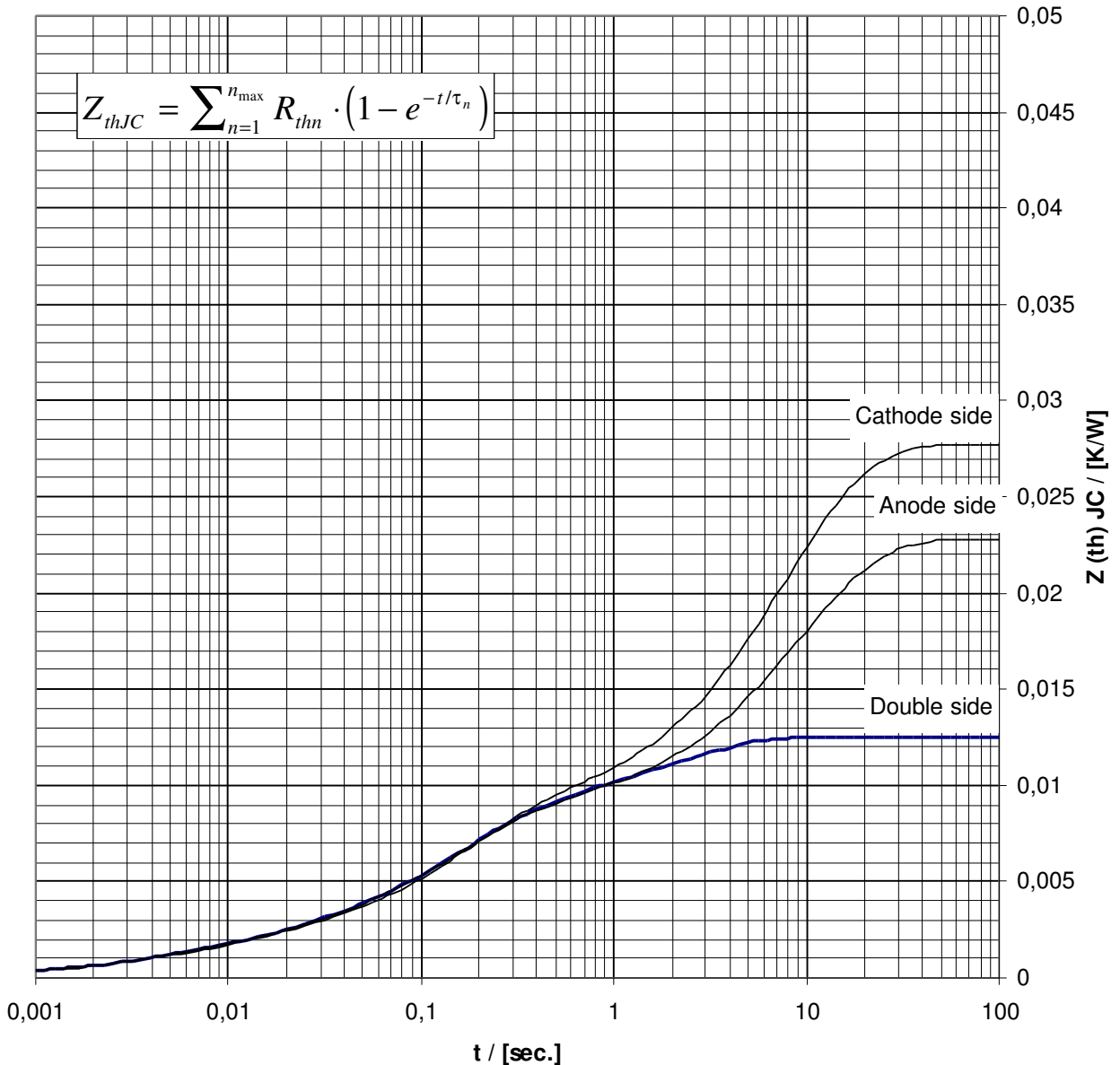

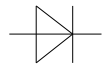

Surge Current Characteristics $I_{FSM} = f(t_p)$
 I^2t value $i^2 dt = f(t_p)$

Sine half-wave, $t_{vj}=140\text{ }^\circ\text{C}$, $V_R = 0$

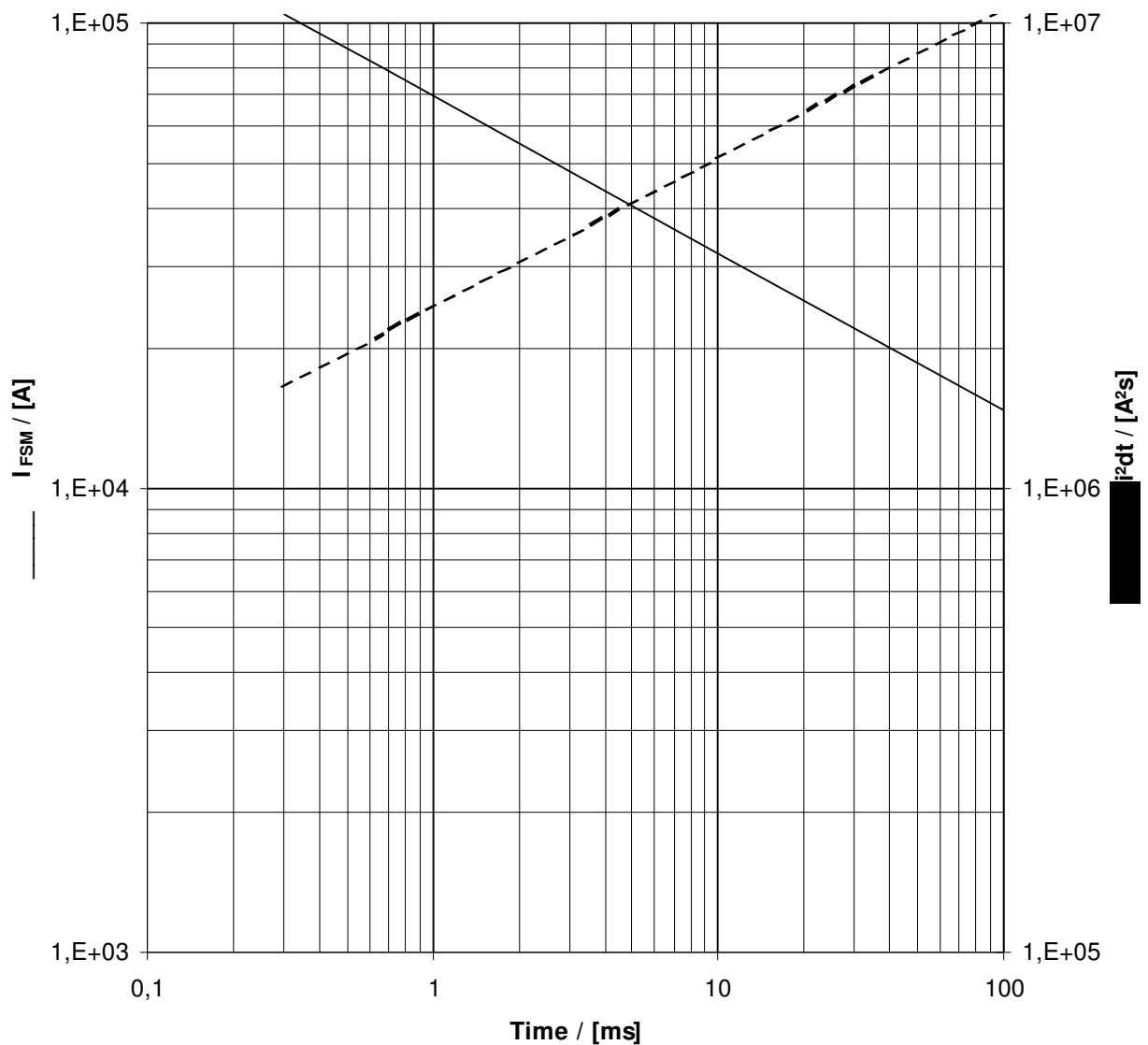

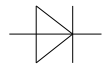

Reverse Recovery Current $I_{RM} = f(-di/dt)$
Upper limit of scatter range

Conditions

: $t_{vj} = 140\text{ }^\circ\text{C}$
 $C_s = 3\text{ }\mu\text{F}$, $D_s = \text{D291S45T}$
 $V_R \geq 1000\text{ V}$

Parameter: I_{FM}

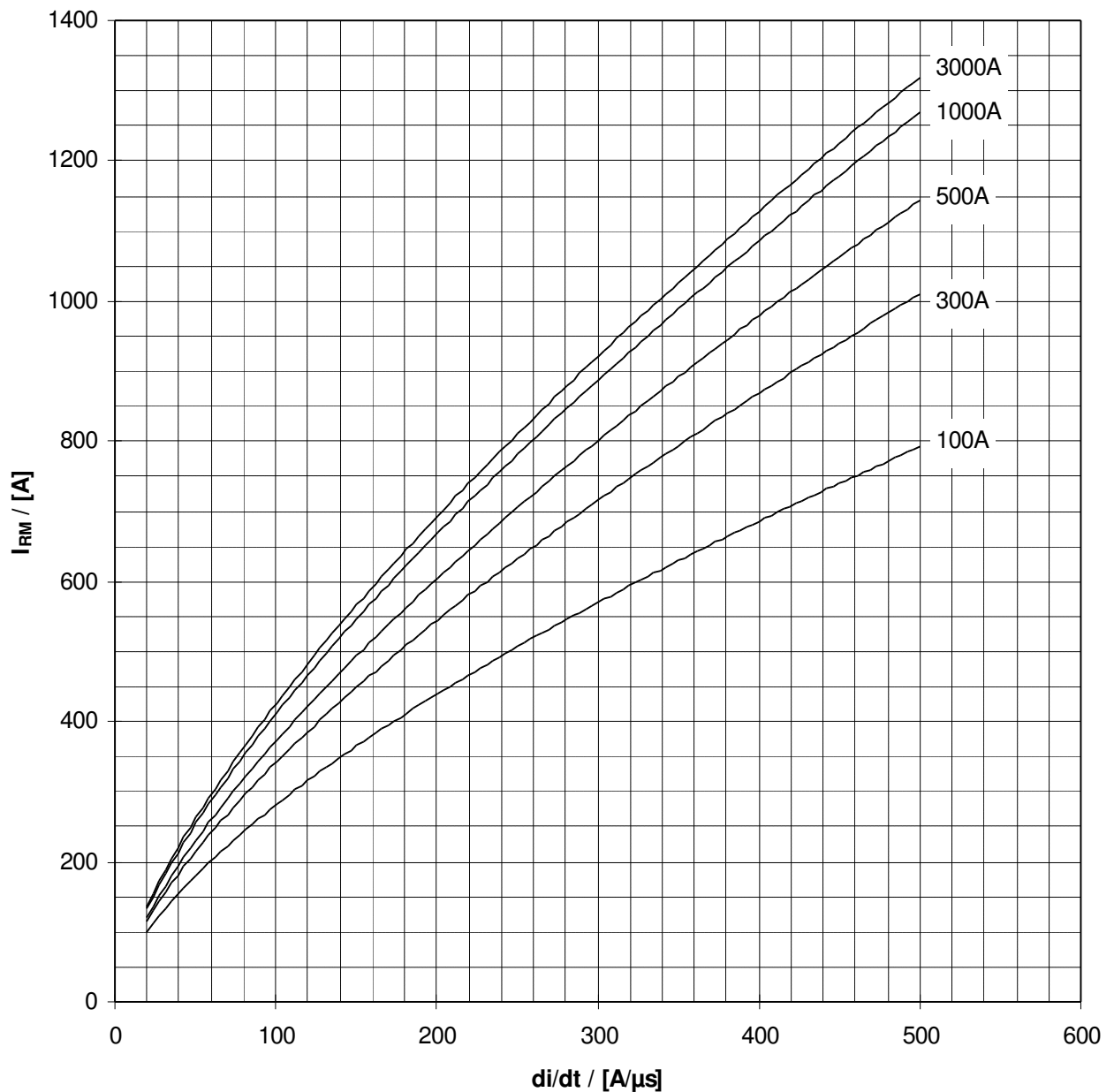

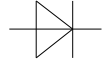

Reverse Recovery Charge $Q_{rr} = f(-di/dt)$
Upper limit of scatter range

Conditions:

$t_{vj} = 140\text{ }^\circ\text{C}$
 $C_s = 3\text{ }\mu\text{F}$, $D_s = \text{D291S45T}$
 $V_R \geq 1000\text{ V}$

Parameter: I_{FM}

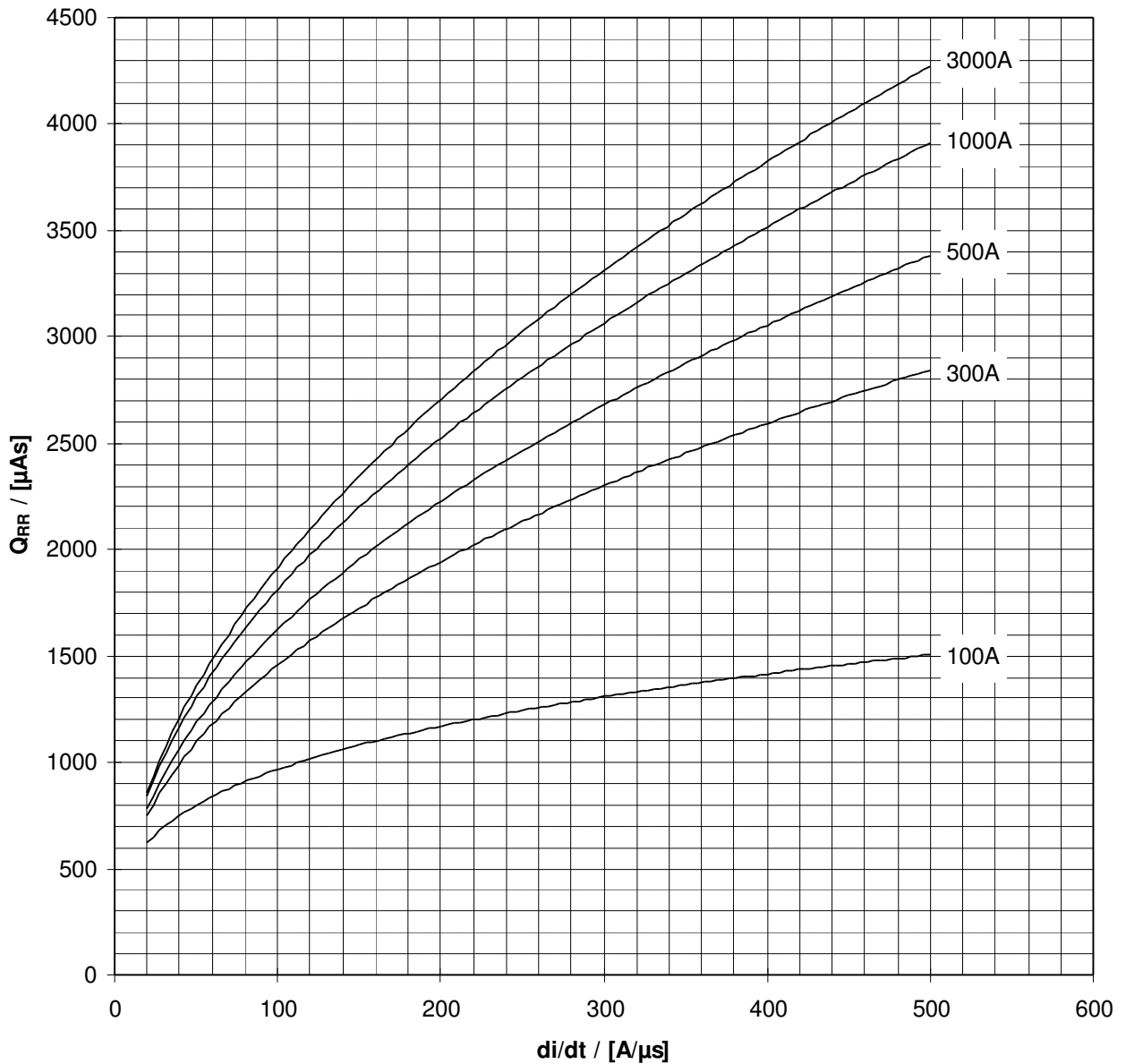

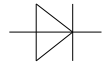

Reverse Recovery Energy $E_{off} = f(-di/dt)$

Standard value for diodes with $V_{T(T0)} = 1,43 \text{ V}$, $r_T = 0,38 \text{ m}\Omega$

Conditions:

$t_{vj} = 140 \text{ }^\circ\text{C}$
 $C_s = 3 \text{ }\mu\text{F}$, $D_s = \text{D291S45T}$

Parameter: I_{FM}
 $V_R = 2000 \text{ V}$ - - - -
 $V_R = 3000 \text{ V}$ _____

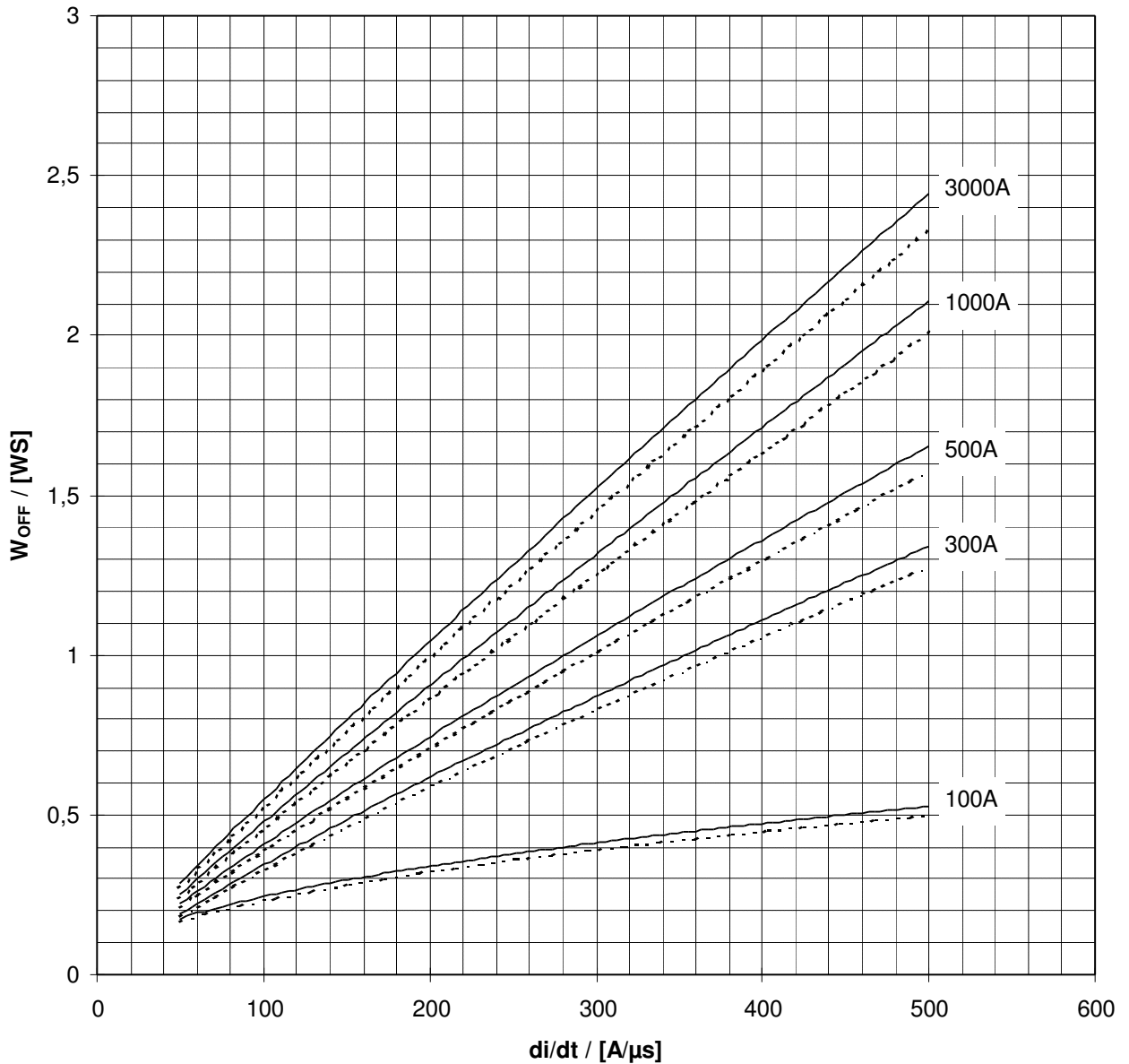

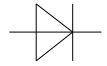

Reverse Recovery Energy $E_{off} = f(-di/dt)$

Standard value for diodes with $V_{T(T0)} = 1,12 \text{ V}$, $r_T = 0,39 \text{ m}\Omega$

Conditions:

$t_{vj} = 140 \text{ }^\circ\text{C}$
 $C_s = 3 \text{ }\mu\text{F}$, $D_s = \text{D291S45T}$

Parameter: I_{FM}
 $V_R = 2000 \text{ V}$ - - - -
 $V_R = 3000 \text{ V}$ _____

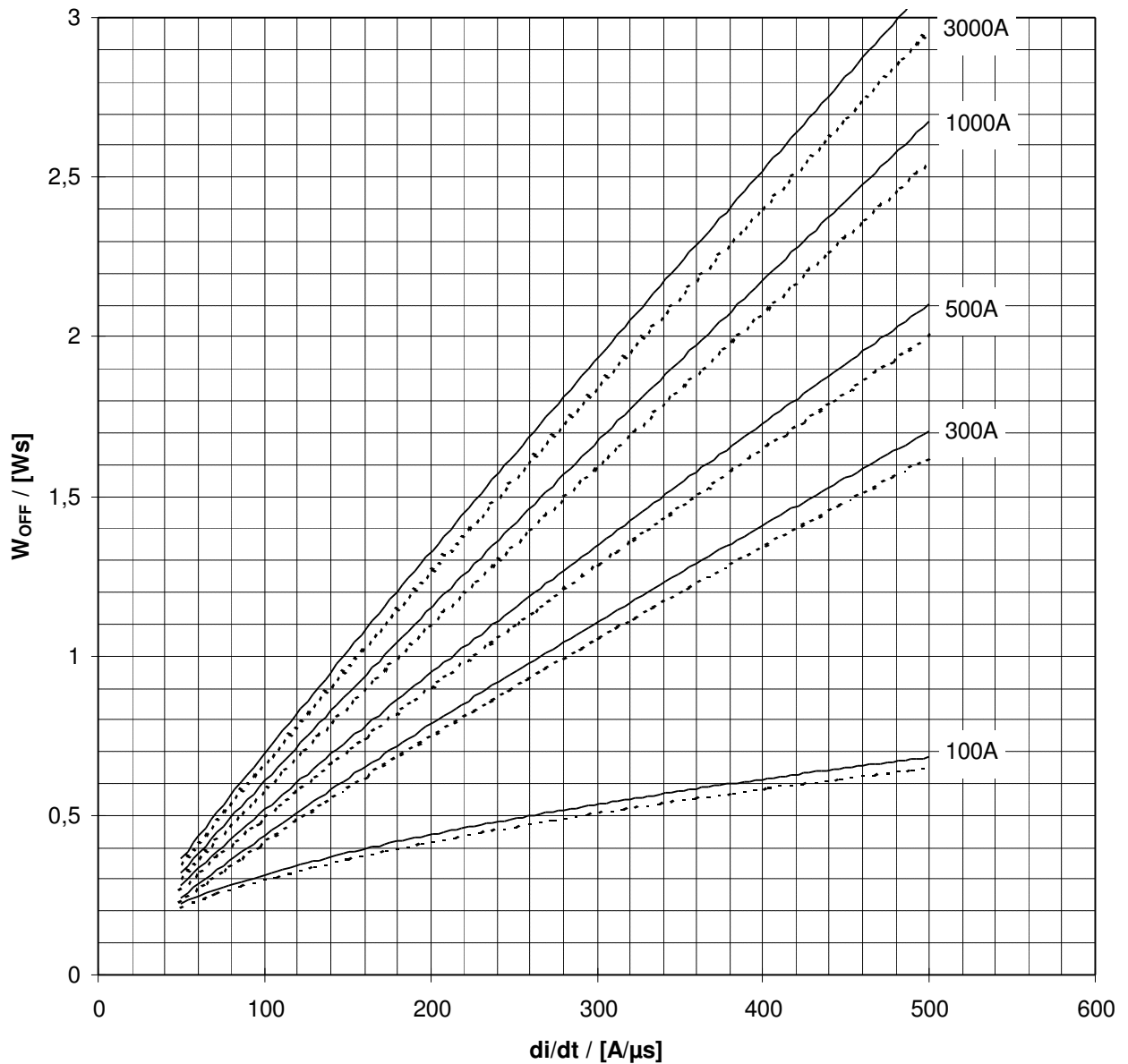

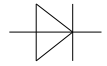

Typical Peak Forward Recovery Voltage $V_{FRM} = f(dI_F/dt)$

linear di/dt
Parameter t_{vj}

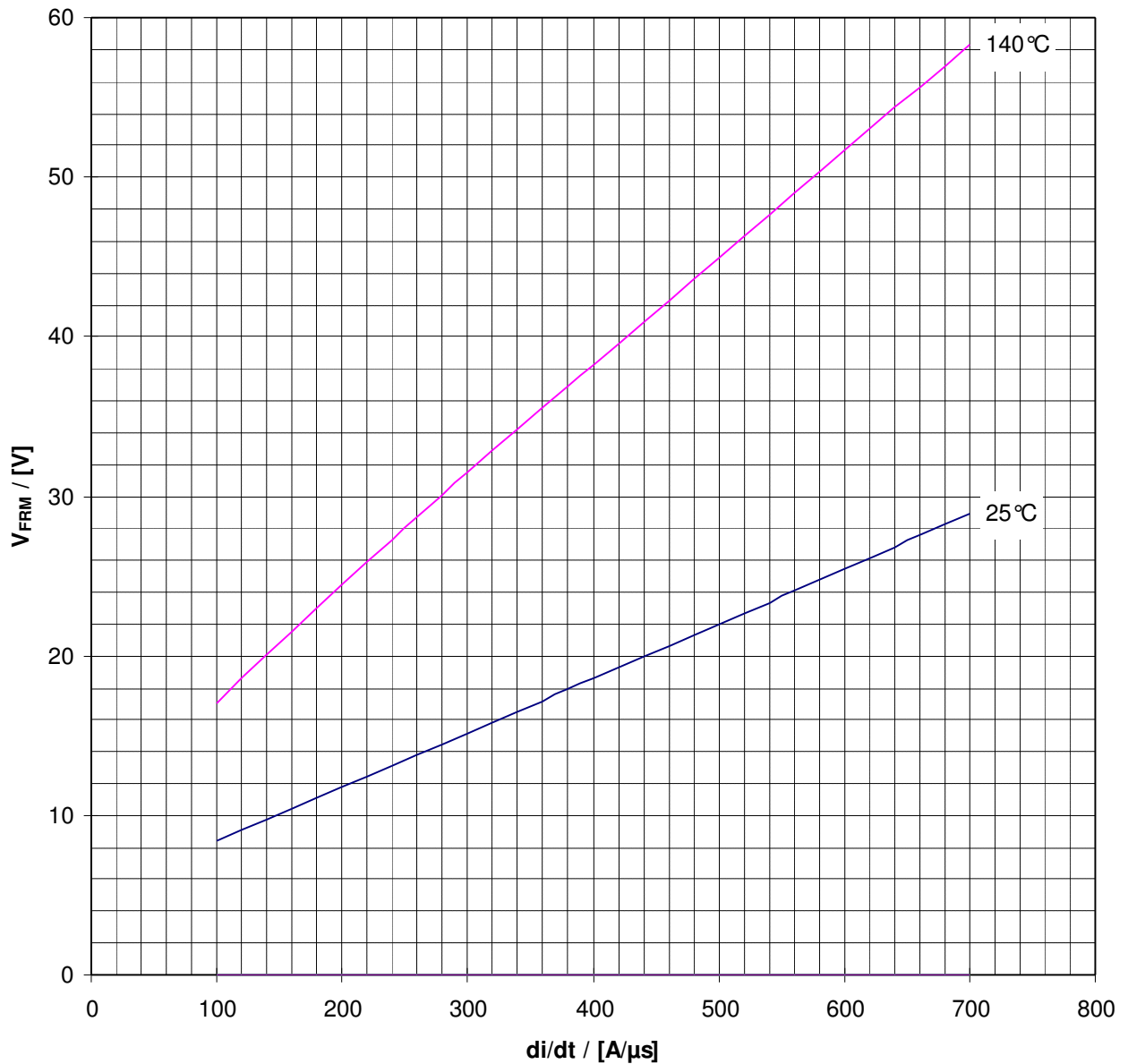

Terms & Conditions of Usage

Attention

The present product data is exclusively subscribed to technically experienced staff. This Data Sheet is describing the specification of the products for which a warranty is granted exclusively pursuant the terms and conditions of the supply agreement. There will be no guarantee of any kind for the product and its specifications. Changes to the Data Sheet are reserved.

You and your technical departments will have to evaluate the suitability of the product for the intended application and the completeness of the product data with respect to such application. Should you require product information in excess of the data given in the Data Sheet, please contact your local Sales Office via "www.eupec.com / sales & contact".

Warning

Due to technical requirements the products may contain dangerous substances. For information on the types in question please contact your local Sales Office via "www.eupec.com / sales & contact".